

GridMon

E N E R G Y M E T E R



Many thanks to our AWS sponsors:
Harout Hedeshian & Chris Goodnow
and incredible Capstone instructors

Motivation

Amazon Web Services provides a highly scalable and low-cost cloud computing platform to hundreds of thousands of businesses and counting. While AWS's services are effortlessly expandable, the data centers that run them are not; in part because of an outdated cable-based energy monitoring system. Despite being subject to wasteful amounts of costly wiring, intermediate translators, pre-construction configuration requirements, and the legacy architecture inherent to cabled meters, these expensive, rigid and unscalable inefficiencies can be easily fixed: wirelessly.

Objectives

GridMon must meet the following minimum sponsor requirements:

- Measure 3-phase current & voltage
- Monitor power factor
- Compute real, apparent and reactive power
- Transmit Wi-Fi data every second
- GPS self-identification

Introduction

GridMon is an energy meter unlike any other. In a nutshell, GridMon takes instantaneous power measurements like a digital multimeter with the additional ability to record total consumption. Unlike a typical multimeter, however, the tool supports 3-phase monitoring with accuracies up to six decimal places after proper calibration, in addition to single-phase. While multi-phase capabilities greatly expand the device's utility, what makes GridMon truly special are its wireless features. On-board Wi-Fi eliminates cables to seamlessly transmit data over the air. Furthermore, an industry-grade GPS enables every GridMon to identify itself, even just a few servers away from other GridMons. These innovations ultimately culminate in a streamlined user interface called Grafana where the information from an entire fleet of meters can populate as soon as they're powered on.

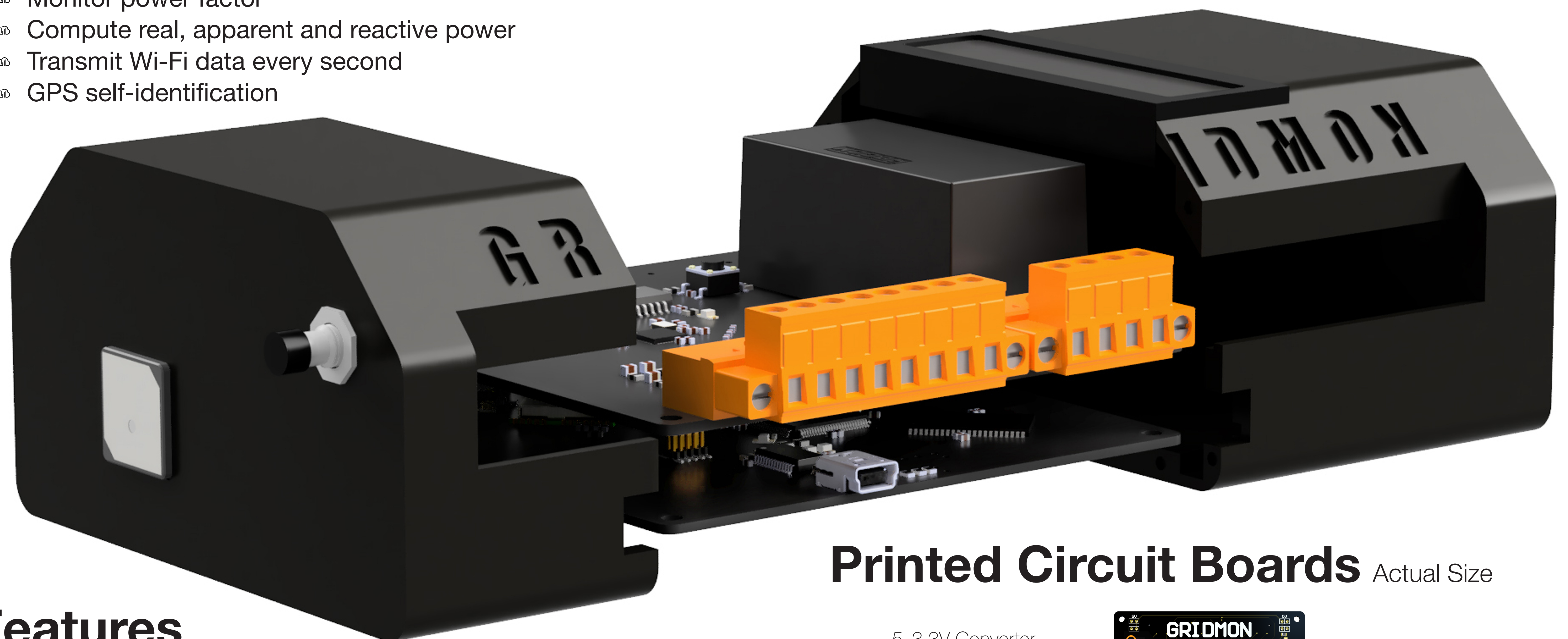

Features

GridMon boasts some of the most advanced features on an energy meter:

- 6 decimal points of accuracy with calibration
- GPS location within 10 m
- No wall outlet or wall wart needed
- Immediate fault detection & alerts
- 3-phase monitoring up to 528 V_{AC}
- Tolerant up to 4 kV_{AC}
- Current transformer support
- Less than 2 minute boot-up time
- Interactive map of energy meters
- Real-time data available online

Printed Circuit Boards Actual Size

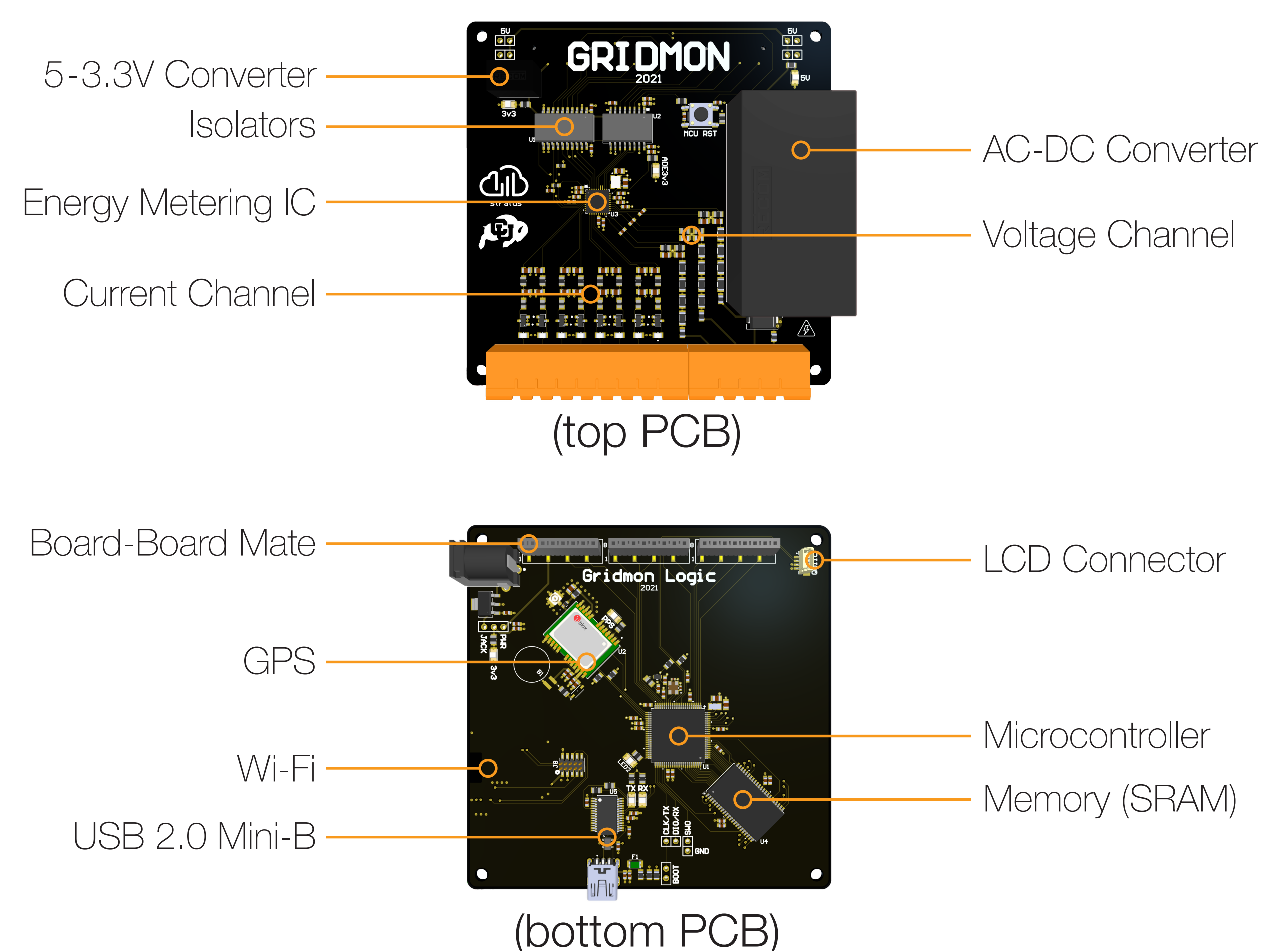

Conclusion

Despite many late nights and invaluable failures throughout this nine month journey, both team **stratus** and GridMon learned and grew along the way. In the end, GridMon's ability to accurately meter energy, monitor and compute power characteristics, self-identify, and wirelessly transmit data in real time surpassed all expectations of success. See for yourself!