



Matthew An  
Logistics Manager

Casey Cole  
Test Engineer

Blake Fardulis  
Project Manager

Kate Nichols  
Manufacturing Engineer

Wesley Schumacher  
Systems Engineer

Andrew Stiller  
CAD Engineer

Aleksey Volkov  
Financial Manager



# Machine Chip Disposal System

## Background

- Accu-Precision: aerospace and industrial manufacturer in Littleton, CO
- Daily machining operations yield hundreds of pounds of metal chips to be recycled
- Recycling process requires machinists to lift and tip bins into large dumpsters by hand
- Dangerous and takes away from machining time

## Current Disposal

- Average one chip disposal per machine everyday ~30 disposals/day
- Disposal process takes two machinists ~15 minutes/disposal
- Human hours: 15 hours/day or ~450 hours/month



## Project Requirements

- ✓ Operable by a single machinist
- ✓ Capable of lifting and disposing up to 600 lbs. of total weight (machine chips and bin)
- ✓ No actuation if swing arm not completely closed
- ✓ No movement of the device when power lost
- ✓ Entire disposal process takes < 10 minutes
- ✓ Compatible with both the large and small bin
- ✓ Safety Factor of ~ 5

## Dumpster Layout

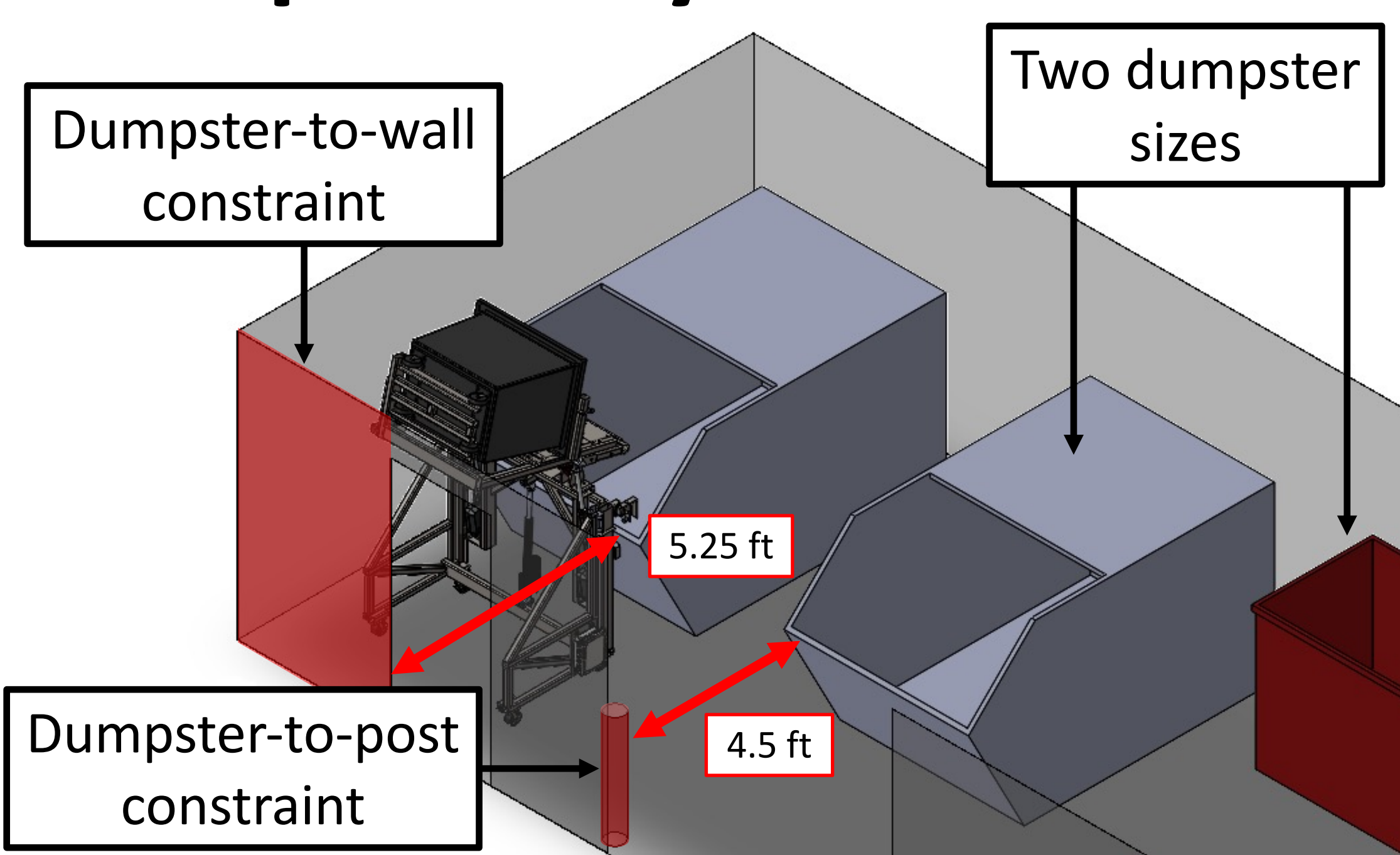

## Machine Design

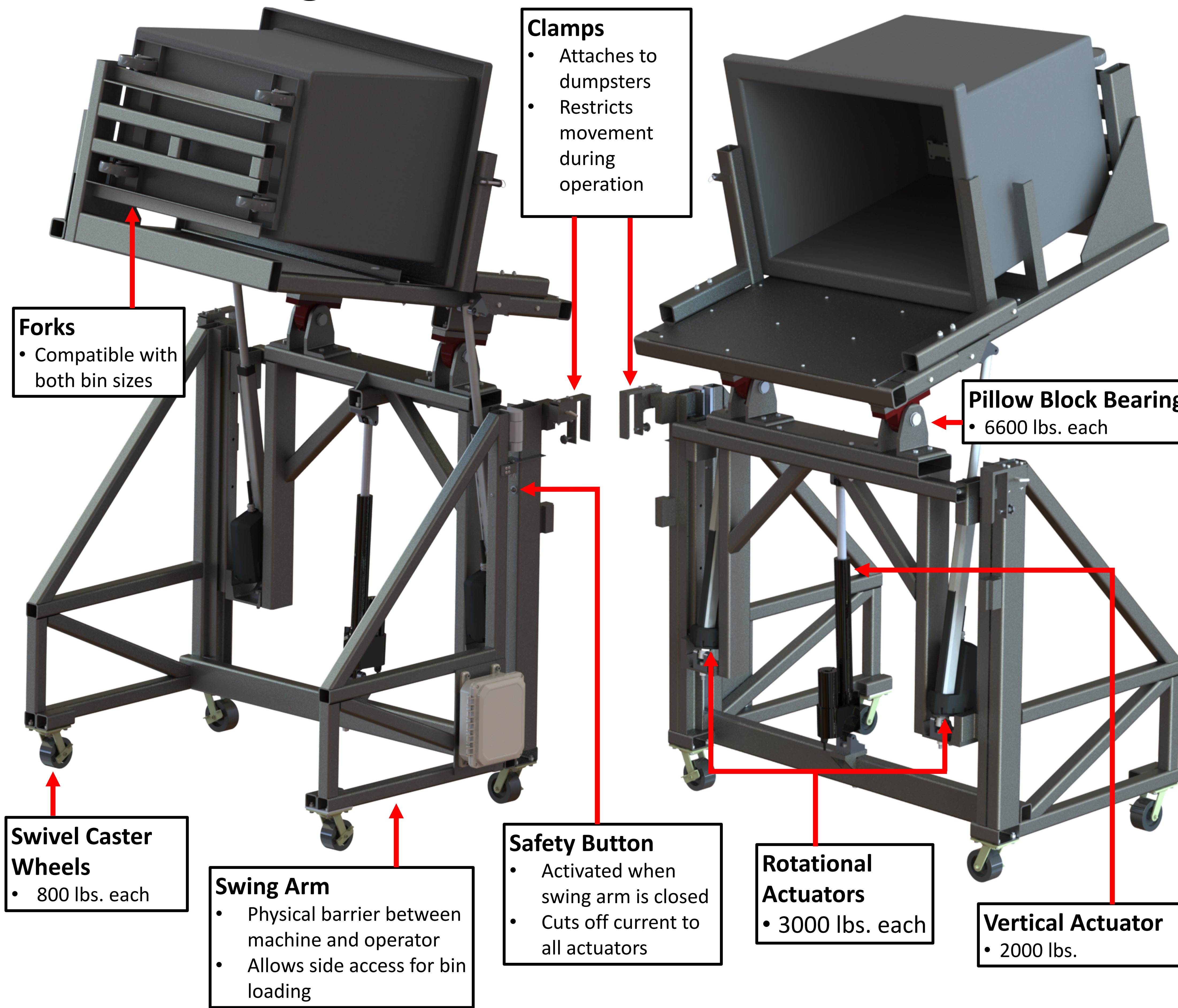

## Simulation Analysis

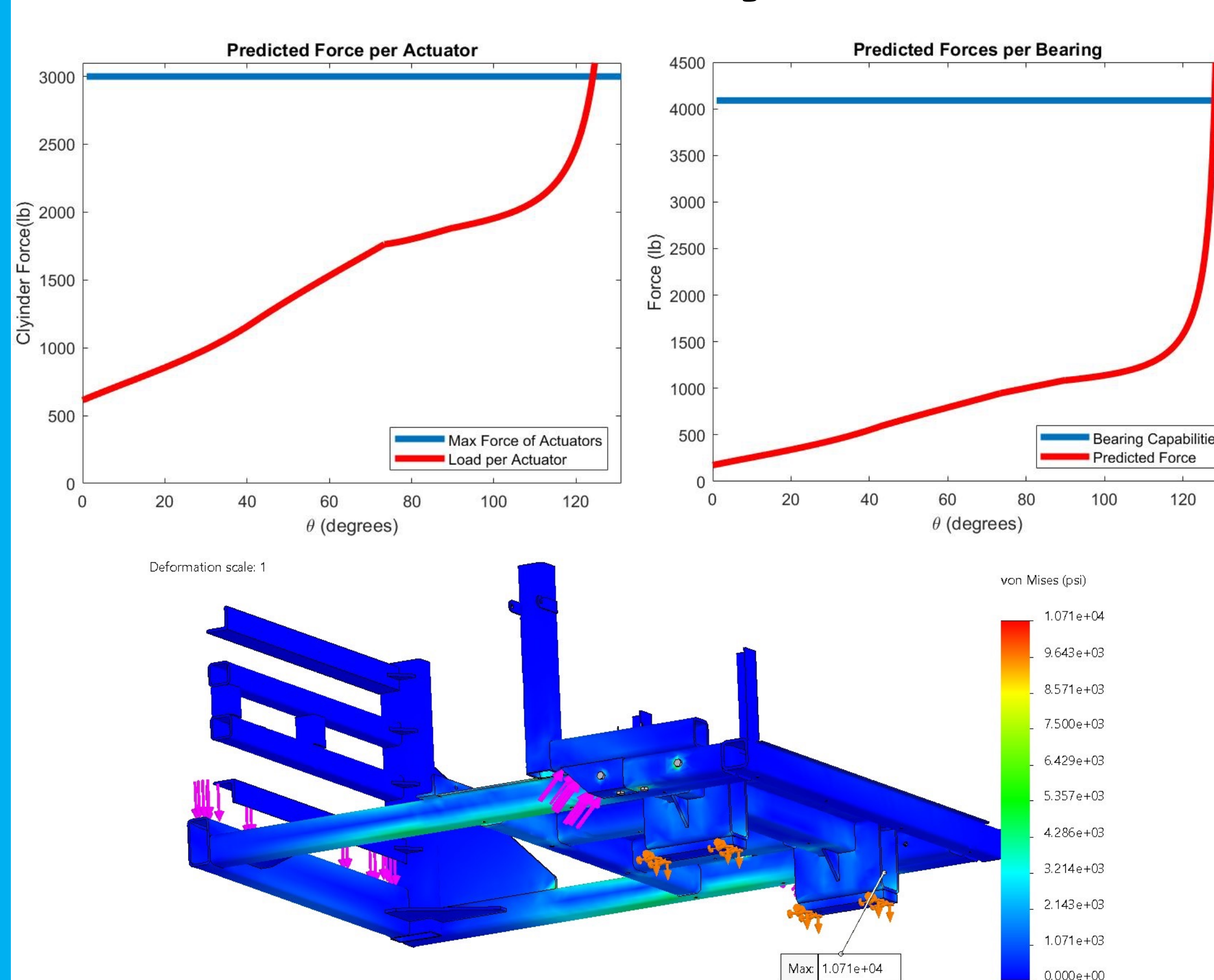

## Electronics

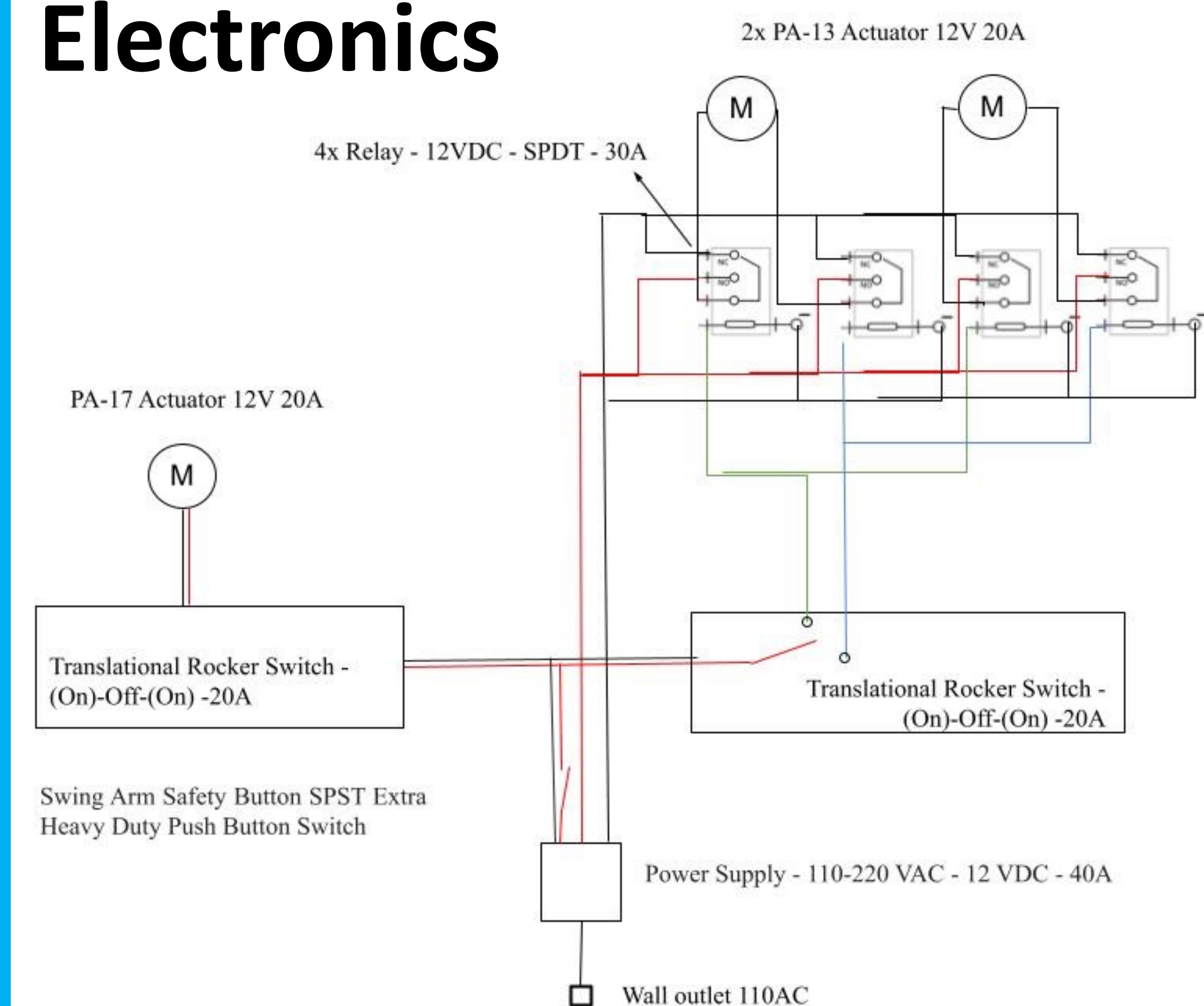

## Machine Motion Process

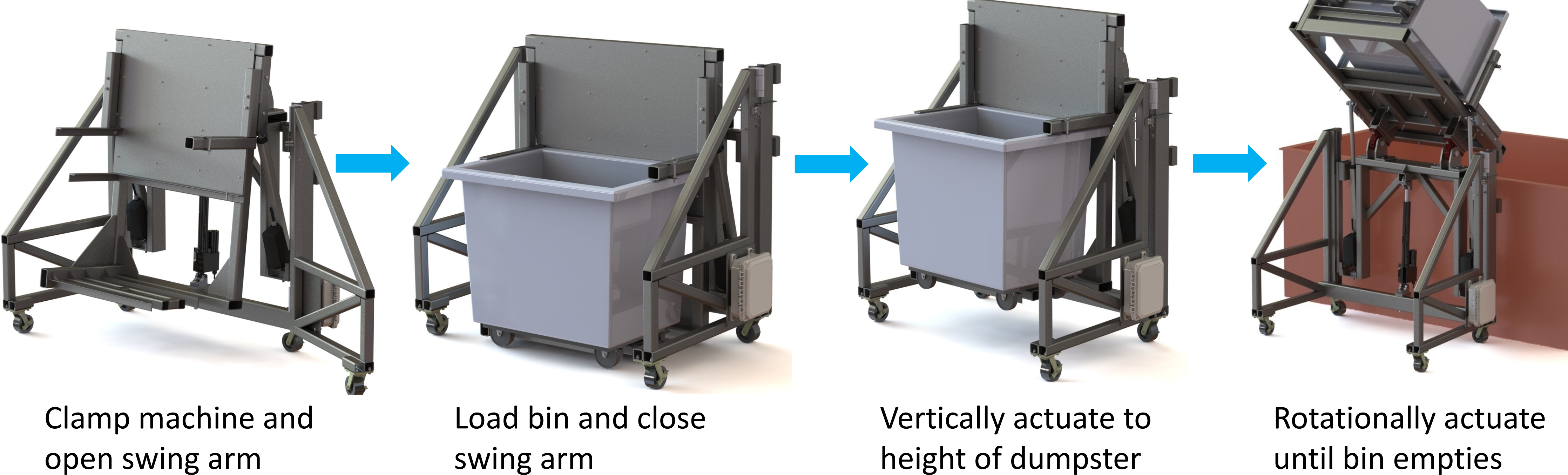

## Safety and Testing

- Device weighs over 1000 lbs.
- Lifts 500 lbs. of chips over 8 ft in the air
- Device has built-in safety redundancies
- Tests basic features and then progresses to full scale
- Pass/Fail testing program logs successes and failures

## Impact

- Saves Accu-Precision ~300 hours/month of time
- Reduces handling time and physical strain
- Increases safety and efficiency in machine shop
- Improves Accu-Precision's company economics

## Acknowledgements

Michael McCue | Alex Doman | Rebecca Komarek | Daria Kotys-Schwartz | Cory Spyres | Shirley Chessman | Julie Steinbrenner | Greg Potts | Chase Logsdon | Pat Maguire | Sean Wilcox

