



# Data Acquisition and Control System Development : Low Speed Wind Tunnel



Malek Alothman, Abdulla Al Sarraf, Felipe Faraco, Spencer Green, Chris Kling, Joe Lopez, Syai Salim, and Yuki Wu

# Table of Contents



p. 03

BACKGROUND



p. 04

INTRODUCTION



p. 5

PITOT TUBE



p. 06

FULL RANGE PRESSURE SENSORS



p. 07

AERODYNAMIC MODEL FORCE BALANCE



p. 08

ELECTRICAL COMPONENTS



p. 09

CONCLUSION

# BACKGROUND

Wind tunnels provide opportunities for people to conduct aerodynamic simulations on a small scale. The ability to test aerodynamics on such a scale is a huge advantage in fast paced markets.

Wind tunnels can simulate conditions from low speeds similar to what aircraft experience during take-off and higher air speeds towards multiple times the speed of sound. Wind tunnels are used in all different kinds of industries including aerospace, automotive, and renewable energy. Wind tunnels are even used in wildfire science to simulate wildfires in a controlled situations.

One advantage of wind tunnels is that the test parameters are readily adjustable. Such parameters are the wind speed, turbulence, and positioning of a model. The forces or moments acting on a model can then be determined efficiently.



Airbus Wind Tunnel (Source: airbus.com)

National Aeronautics and Space Administration



## Open Return Wind Tunnel

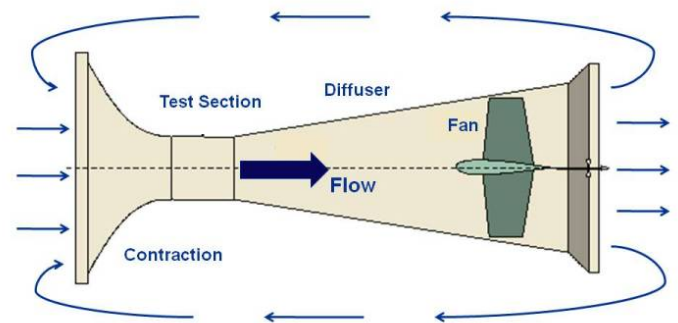

www.nasa.gov

Wind Tunnel (Source: grc.nasa.gov)

# INTRODUCTION

The aim of this project was to build onto an existing wind tunnel. Our client, Answer Engineering, asked us to develop a system which could measure forces on a model and gather pressure readings. In addition, we also chose to pursue an automated positioning system for the models.

In the upper right figure, a CAD rendering of the existing test section with our additions can be seen. We created a model positioning system for scale models of aircraft and wing configurations. The system will be able to output critical experimental information.

The desired model information are the lift force and pitching moment. While, the desired environment information is the wind speed and pressure variance in the test section.

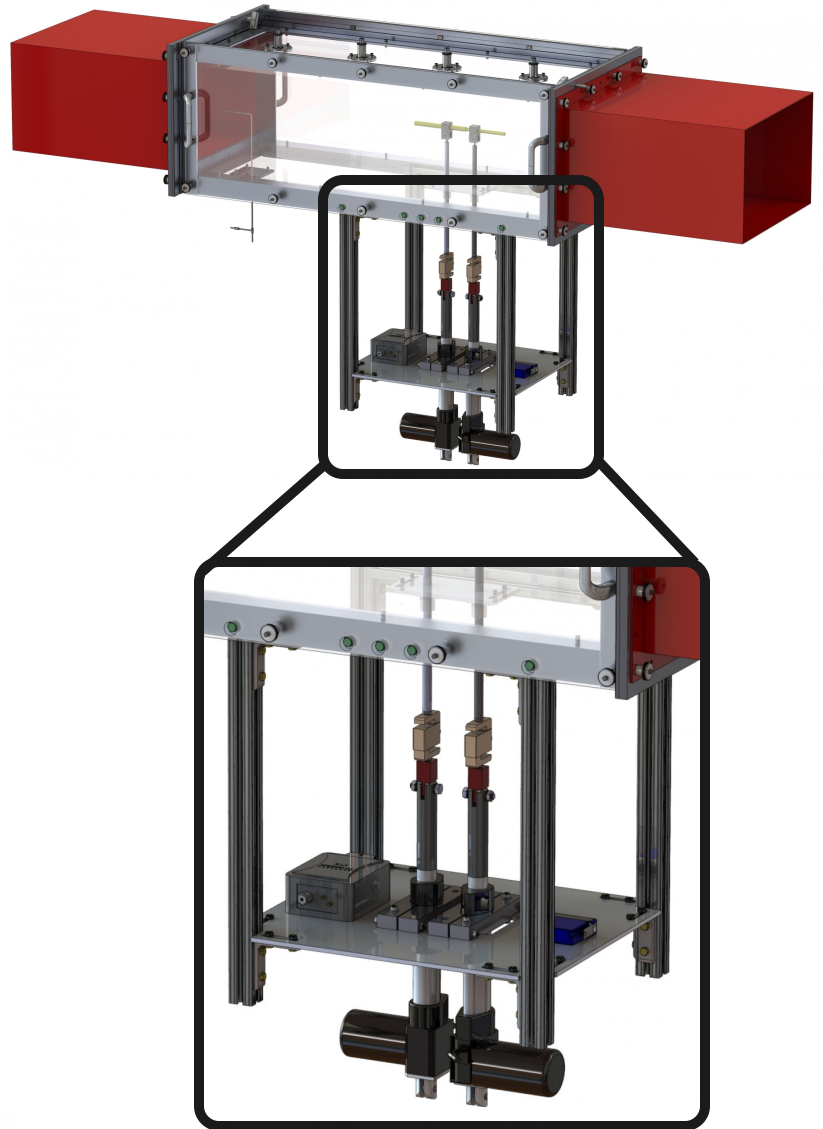

Answer Engineering Wind Tunnel Test Section



Wind Tunnel Positioning System

# PITOT-TUBE

The first addition that we made to the wind tunnel test section was the implementation of a pitot tube. The pitot tube is a slender tube that has two ports for air. The front holes on the end are pointed into the air stream to measure stagnation pressure. The side ports around the cylinder measures the static pressure.

The two nozzle exits of the pitot tube are connected to the differential pressure sensor to measure the air velocity inside the test section. Air velocity measurements are critical to accurately analyze as they appear in numerous fluid mechanic equations.

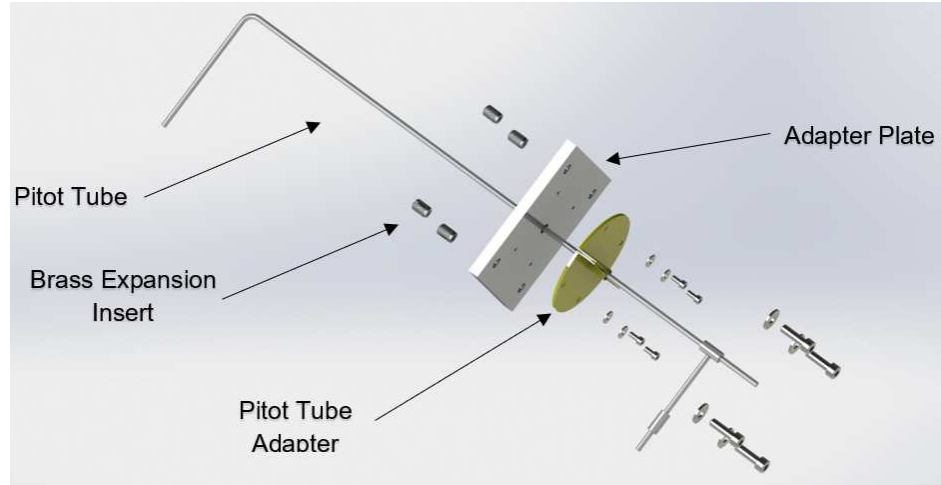

Exploded View of the Pitot Tube



Differential Pressure Transducer

The differential pressure transducer is used to read the pressure difference between the two pressures of the pitot tube. The differential pressure transducer chosen for our project is the A/DLP-10 seen in the picture on the left.

This differential pressure transducer was selected for its precision. In addition, it also features an on board digital display to allow for quick pressure inspections. The pressure transducer outputs a voltage signal to the data acquisition system.

From here, our team takes this data and uses the Prandtl equation below to calculate the air velocity.

$$v = \sqrt{\frac{2 * \Delta P}{\rho}}$$

Prandtl's Equation



# PRESSURE SENSORS

In addition to the pitot tube, it is necessary to capture the static pressure within the wind tunnel at various positions. We went forward with DWYER 2HVL3 sensors after a trade study revealed that they offered the highest precision for the best price.

The pressure sensors' primary function is to convert static pressure into an electric signal that connects to a data acquisition system. The pressure measured at each point will be displayed on a graphical user interface.

The pressure sensors are installed within a customized adapter plate in order to attach them on the top panel of the test section. This mounting process proved to be one of the toughest challenges for our team as the sensor needed to be flush with the adapter and the plexiglass panel.

The pressure sensors use a 1/4"-NPT thread to mount into the adapter plate. This was out of our control and required our team to conduct further work. Using a drop gauge, we adjusted the counter-sink of each adapter until all sensors were at the correct depth.

The figure on the bottom right shows the four static pressure sensors located along the center line of the top panel. There will be two pressure sensors on top of the aerodynamic model and another two at the both ends of the test section. This allows for detecting pressure changes associated with different aerodynamic models.

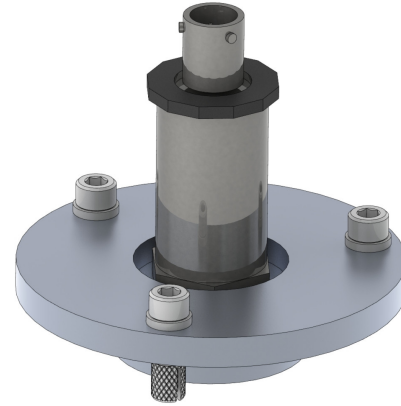

Static Pressure Sensor Assembly

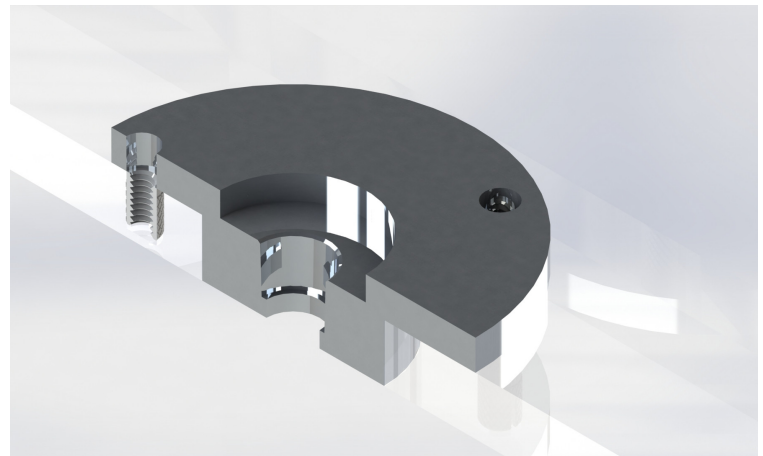

Cross Section of the Adapter

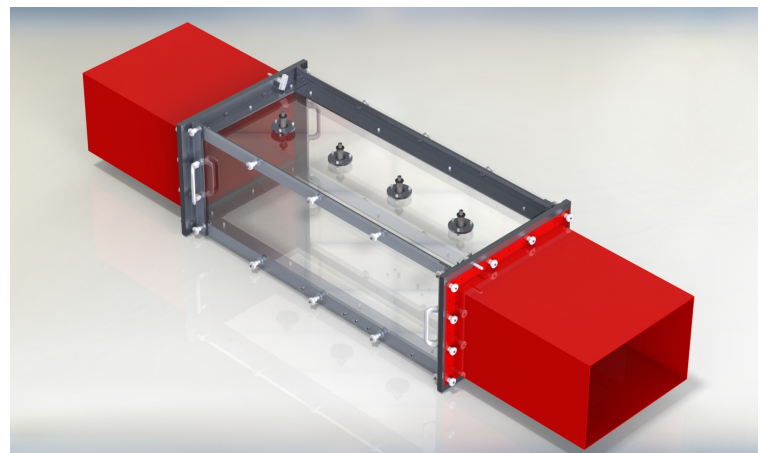

Location of Sensors on Test Section

# AERODYNAMIC MODEL FORCE BALANCE

The force balance and positioning system posed the largest challenge of our project. It utilizes a pair of linear actuators to change the vertical position as well as the angle of attack of the aerodynamic model. There are two S-Type load cells that collect axial forces within the support beams. Using these measured forces, we can then calculate the lift force on the model within DASyLab, a data acquisition software.

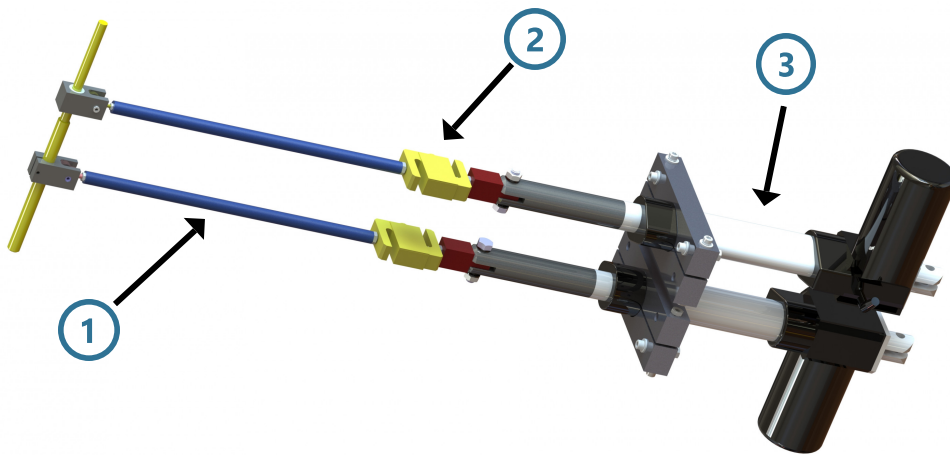

## Part Name

1. Support Beam
2. S - Load Cell
3. Linear Actuator

Force Balance

There were two main struggles that caused this part of the project to be difficult. Converting the load cell measurements into the lift forces that we would expect and correctly calibrating the linear actuators. Given that the load cells are only capable of capturing axial forces required that our design be precise in its approach. For the linear actuators, our team encountered problems with obtaining consistent vertical displacements for a given amount of pulses. However, through further testing we managed to correct this issue.

The Sting is the place where aerodynamic models are mounted. It features a linear bearing on the Rear Sting Clamp that allows the angle of attack to change from vertical displacement. There are rod ends on each support beam that allow this axis of rotation. This is a critical part of our design as its precision determines the accuracy of our lift force calculations.

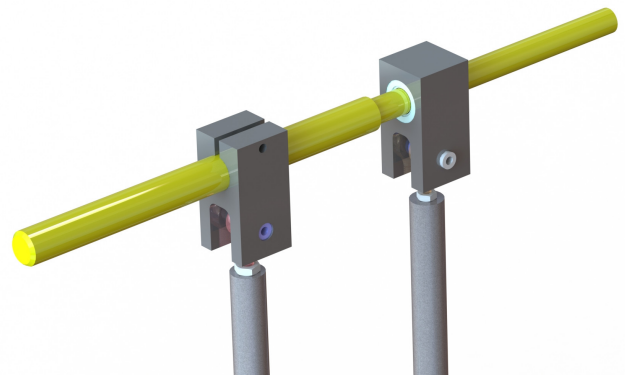

Sting Assembly

# CONTROLLING THE POSITION

One of our goals was to allow the user to control the height and angle of attack of the model from a computer. To solve this problem, we created custom software and hardware to communicate the user's instructions down to the linear actuators, and let the actuators communicate their positions back.

## Sending a Command:

First, the user can type in a command - either an angle or a position - into a Python script the team wrote, which calculates where to put the actuators to achieve this aim, and then sends a packet of information over USB to the microcontroller.

The microcontroller, a Silicon Labs Leopard Gecko, is mounted on a custom printed circuit board, which connects it to the USB port, as well as the pins used to control the actuators. Based on the packet it gets over USB, the microcontroller sets these pins to extend or retract the actuators appropriately and waits for feedback from the actuators.

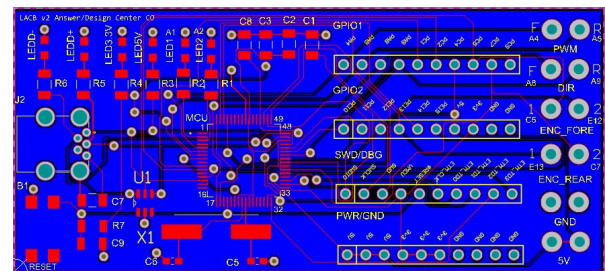

Printed Circuit Board Layout

While extending or retracting, the linear actuators send information back from their Hall Effect encoders. When the motors that move them turn, these encoders create two offset electronic signals, which indicate which direction the actuators are going depending on whether signal 1 or signal 2 leads the other. The microcontroller takes these pulses in and counts them to keep track of the actuators' position, and stops them moving when they reach the position the user indicated.

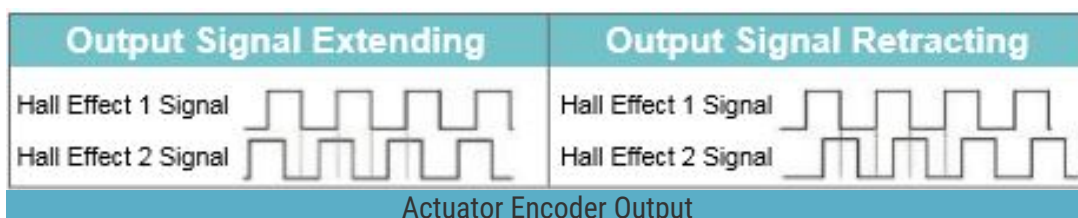



# CONCLUSION

Our team strives to ensure that our project meets the professional standards of our instructor and client. Due to recent circumstances we were unable to achieve all that we had hoped to, our team designed and created a system capable of meeting our client's expectations. We are proud of the progress that we made and thankful for the opportunity that we had.

# OUR TEAM



Team 18  
Answer Engineering

Yuki Wu	Syaifuddin	Joseph Lopez	Christopher Kling	Spencer Green	Felipe Faraco	Abdulla Al Sarraf	Abdulmalek Alothman
System Engineer	CAD Engineer	Electrical Engineer	Financial Manager	Project Manager	Logistic Manager	Manufacturing Engineer	Test Engineer

## SPECIAL THANKS:

Dr. Gerard Carroll, Patrick Hipp, Kasey Baker, Kelly Wotkyns, Daniel Sinner, and Elliot Guber